

# jurnal ilung

*by Ilung Imei*

---

**Submission date:** 04-May-2023 02:03PM (UTC+0700)

**Submission ID:** 2083864508

**File name:** 9945-34821-1-SM\_1.docx (1.09M)

**Word count:** 4206

**Character count:** 22637



# System Telemetry for Mobile Devices Using the GPS Neo-6M and DHT11 Modules A Case Study by IMEI Team

Cholilurrohman<sup>a,1</sup>, Indah Sulistiyowati<sup>b,2\*</sup>, Arief Wicaksono<sup>b,3</sup>

<sup>a</sup>Electrical Engineering Department, Universitas Muhammadiyah Sidoarjo, Indonesia

<sup>1</sup>Cholilurrohman18@gmail.com, indah\_sulistiyowati@umsida.ac.id, Ariefwicaksono@umsida.ac.id

\*corresponding author: Indah Sulistiyowati

## ABSTRACT

3

### Keywords

Formula One (F1)  
Shell Eco-Marathon  
(SEM)  
Kontes Mobil  
Hemat Energi  
(KMHE)  
Telemetry System,  
Internet Of Things,  
Sensor DHT11

3

Telemetry systems are used during Formula One (F1) and Shell Eco Marathon (SEM) races to monitor car conditions and performance during the race. This telemetry system is designed to monitor the performance of the car in real time by obtaining data about speed, steering room temperature, and other parameters. The purpose of making this tool is to be able to strategize during a good and efficient race. In this research on telemetry system development, several sensors and electronic devices are used to monitor car performance. This telemetry system consists of several sensors installed on the car, such as the U-blox Neo 6m GPS sensor and the DHT 11 sensor. These sensors collect data and transmit it to the control unit, which then sends the data to the server. The method used in this research includes several stages, namely telemetry system development, trials and testing, and data analysis. The main result of this research is the development of a telemetry system that can monitor the performance of electric cars in real-time. This telemetry system can provide useful information for the driver on the track and the team at the track. In addition, the results of this research also show that the telemetry system developed can produce accurate and reliable data. An electric telemetry system can be a very useful tool for electric car users and manufacturers in improving the efficiency and performance of electric cars. In this study, the development of the telemetry system has successfully produced a tool that can monitor the performance of electric cars in real time and provide useful information for users and electric car manufacturers. It is hoped that the results of this research can help in developing more efficient and environmentally friendly electric car technology in the future.

## 1. Introduction

Formula One was the first motorsport competition held in 1950, IndyCar was the first in America, and MotoGP was the first in 1949 [1]. System telemetry collects data from a car or motor during acceleration, such as speed, engine efficiency, temperature, etc[2]. The mechanical team uses this information to maximize motor or mobile work efficiency during the battle. The telemetry system is used in mobile competitions like the Shell Eco-Marathon (SEM) [3].

The Shell Eco-Marathon is an international competition for students to design, construct, and operate energy-efficient automobiles. The objective of this competition is to encourage students to think creatively about ways to reduce the environmental impact of transportation by developing new and innovative ideas for more sustainable modes of transportation. This could include ideas for electric vehicles, alternative fuel vehicles, car-sharing programs, bike-sharing programs, or other forms of transportation that reduce emissions and conserve resources. By focusing on maximizing fuel economy, the competition encourages students to consider the most efficient ways to power vehicles and minimize their environmental impact [4]. Students must create, construct, and operate cars in the prototype and urban idea categories for the Shell Eco-Marathon competition. Vehicles built to travel the greatest distance with the least amount of energy fall into the prototype category. These cars frequently feature streamlined designs and aren't always viable for usage on public roads. The urban concept category is for automobiles that are intended to be more useful for usage in urban settings, focusing on comfort, safety, and energy economy[5].





In Indonesia, the Shell Eco-Marathon is also staged as the "Kontes Mobil Hemat Energi" (KMHE), a national competition. Shell Indonesia and the Ministry of Energy and Mineral Resources organize it. Similar competitions encourage students to create, assemble, and operate energy-efficient cars like KMHE. The competition aims to encourage sustainable transportation and energy conservation in Indonesia. The nationwide tournament is organized annually and is available to students from universities, polytechnics, and vocational institutions [6].

The contest you referring to was once called the Indonesia Energy Marathon Challenge (IEMC). It was run annually by the Ministry of Research and Higher Education (DIKTI) in collaboration with Shell Indonesia. The competition's objectives were to inspire Indonesian students to create energy-efficient automobiles and to employ alternative energy sources for transportation [7]. By holding these challenges, the government encourages students to come up with novel transportation solutions and contributes to educating the next generation about the value of energy efficiency and environmental preservation. Additionally, it gives students a place to practice and expand their expertise in the areas of energy efficiency and sustainable mobility. Additionally, it supports the government's objective to boost the use of renewable energy sources while reducing its reliance on fossil fuels. [8].

The objective of contests like the Shell Eco-Marathon and other student-led vehicle competitions has evolved to focus on developing concepts for future energy-efficient vehicles as the world comes under increasing pressure to reduce its reliance on fossil fuels and stop the effects of climate change. The competition invites students to go beyond the state of technology today and to concentrate on creating ground-breaking ideas that can be used in the future to improve transportation sustainability. [9]. A car that uses less energy or gasoline to drive a specific distance is referred to as an energy-efficient car or a fuel-efficient car. The prototype category's design goals are to achieve the maximum feasible fuel economy, frequently through lowering the vehicle's overall weight and utilizing aerodynamics [10]. Prototype and urban idea are the two competition categories for Kontes Mobil Hemat Energi (KMHE).

Various energy sources propel vehicles from both categories. Vehicles with internal combustion engines (ICE) and electric motors are permitted in the prototype category. Vehicles powered by internal combustion engines (ICE), hydrogen fuel cells, solar electricity, and other alternative energy sources are all permitted in the urban idea category [11]. The overall objective of the competition is to promote sustainable mobility by supporting the development of energy-efficient cars that consume less energy and emit fewer pollutants. Aiming to inspire the next generation of engineers, researchers, and leaders work on sustainable transportation solutions, competitions like the Shell Eco-Marathon (SEM), Kontes Mobil Hemat Energi (KMHE), and Indonesia Energy Marathon Challenge (IEMC) encourage the development of energy-efficient vehicles.

The motorsports sector depends heavily on telemetry technology, which is rapidly developing [12]. Every year, telemetry system improvements are made to give teams more precise and thorough information about the performance of their vehicles [13]. This information may be utilized to customize the vehicle's settings for various courses and weather situations and increase the vehicle's performance during the race [14]. Electric vehicle (EV) development and racing competition use are anticipated to rely on telemetry systems heavily [15]. Teams can get precise data from telemetry systems on the operation of the electric drivetrain, including details on the battery charge, power consumption, and temperature control. This information may be utilized to enhance the powertrain's overall efficiency and the vehicle's performance during the race [16]. A vehicle's performance may be monitored and controlled via telemetry systems, which are used to capture and send data from the vehicle in real-time [17].

## 2. The Proposed Method

In analyzing the system to be implemented, there are reviews of several previous journals. The first journal describes the telemetry system of the imei-based Umsida electric car based on IoT and Ublox GPS Neo-6M [14]. The next journal is about Telkom University's IoT-based Inacos electric car telemetry system. [3]. In this tool, a tracker sensor is used to determine the motor rpm and speed of the electric car, which will be read by Minipic before being displayed on the LCD and client server.





The needs analysis is performed by analyzing the components required for the general performance of the telemetry system[18].

## 2.1. Telemetry System

Telemetry systems are used in motorsports to track various data, including speed, engine RPM, temperature, fuel consumption, tire pressure, and many other factors that might impact a vehicle's performance[19].

## 2.2. Internet of Things

Technology development has enabled the Internet of Things (IoT) to be integrated into telemetry systems, enabling real-time data gathering, analysis, and transfer via the internet[20]. This enables teams and engineers to access the telemetry system's acquired data remotely and retain and analyze the data over time[21].

7

## 2.3 GPSU-blox Neo 6m

The U-blox Neo 6M GPS module is a GPS signal receiver module that interfaces with the Nodemcu ESP8266 microcontroller, is the GPS module utilized in this telemetry system. The U-blox Neo 6M GPS module is a high-performance, power-efficient module that offers precise position information. It can receive signals from several satellite constellations, such as GPS, GLONASS, Galileo, and BeiDou, and it can still offer highly accurate position information in difficult conditions. After integrating this module, the system will track the vehicle's location and motion in real time and offer precise location data [22].

## 2.4 Sensor DHT 11

The DHT11 temperature sensor is another sensor incorporated into the telemetry system. The temperature in the cockpit of the car is measured using this sensor. A digital signal, or a numeric value that indicates the temperature, is what the sensor will produce. This sensor measures humidity and temperature digitally at a reasonable cost. It takes measurements of the humidity and temperature in the surrounding area, transmits the information to the microcontroller for processing, and then communicates the results to the user through the internet. This sensor will come in handy for keeping an eye on the temperature inside the car, especially when it is parked. By doing so, it will be able to warn the driver if the temperature inside the car is outside of the intended range and help to avoid damage brought on by high temperatures [24].

## 2.5 NodeMCUESP 8266

The Nodemcu ESP8266, which serves as the telemetry system's brain, is an additional setup component. The ESP8266 is a microcontroller module that can connect to the internet or a wifi network and interface with various programmable sensors. The DHT11 temperature sensor and the U-blox Neo 6M GPS module are two examples of sensors that can communicate with this microcontroller. They can also interpret sensor data and transmit it to the user via the internet. Additionally, it will handle communication between the user's gadget and the system, enabling remote system monitoring and management [25].

## 3. Method

The scientific methods for developing an electric vehicle telemetry system use a GPS Neo 6M module and a DHT 11 sensor. The case study of the UMSIDA IMEI team consists of a literature





review, needs analysis, design, implementation, and testing. The literature review is used to understand various issues and alternative solutions that can be used to solve the problem. The needs analysis is then performed to determine the system performance requirements and the necessary system components. The design includes block diagrams and system flow diagrams. The design is then implemented in the production phase. Finally, to evaluate the system's effectiveness, the system is tested. Figure 1 illustrates the research stages carried out for developing an electric vehicle telemetry system using a GPS Neo 6M module and a DHT 11 sensor as part of the UMSIDA IMEI team case study.

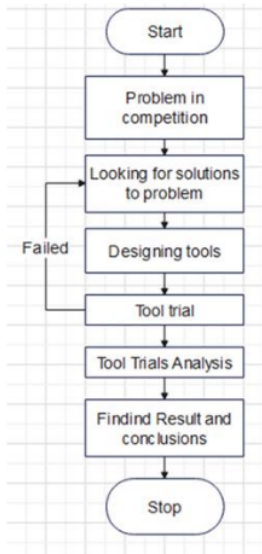

Fig 1. Research stages

After that, the general architecture of the telemetry system is created, which will be useful in determining the system's basic design. The system architecture is shown in Figure 2.

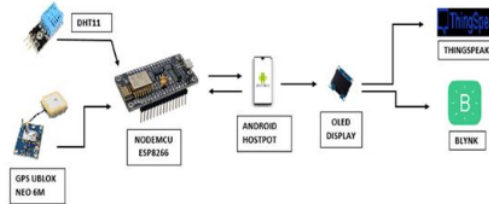

Fig 2. The general architecture of a telemetry system

The picture above it can be seen in general the description of the tools that have been made as follows:

1. NodeMcu ESP8266 is a microcontroller for communication between other components and wifi that communicates with the internet.
2. U-blox GPS Neo 6m as a GPS sensor to generate data in the form of location data (longitude and latitude), speed, distance and satellite, cardinal, and time. The data is obtained through detected satellites.
3. The DHT 11 sensor is a data readout to get room temperature data for car parts.
4. Satellites are used to find locations detected by satellites and then connected to a GPS device.
5. Blynk is a display place for displaying data obtained via Android.







6. Thingspeak receives data sent by nodeMCU via HTTP and displayed via the web server.

The next stage is to program the microcontroller to perform the required operations after the general architecture of the telemetry system has been designed. The C programming language is frequently used for microcontroller programming. It is an excellent option for the competition because it is reasonably easy to learn but strong enough to handle challenging jobs. The C code can be written, compiled, and uploaded to the microcontroller using the widely used software development environment called the Arduino IDE. It comes with a C compiler and some libraries and tools that make it simple to connect with the many telemetry system components, such as the GPS receiver, sensors, and communication interfaces, and program the microcontroller. The Arduino IDE software may be seen in the image below.



Fig 3. Display of the Arduino IDE

After the system program has been completed, determine the flow diagram of the telemetry system program. The following shows the flowchart of the electric car telemetry system program using the Neo 6m GPS module and the DHT11 sensor, a case study by the Umsida IMEI team.

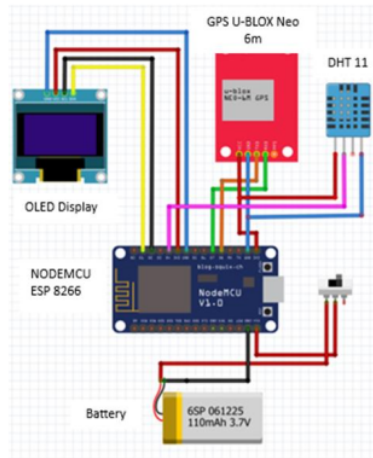

Fig 4. Hardware series





**Table 1.** NodeMCU Port Usage

No.	NodeMcu port	Usage
1	D1	SDA
2	D2	SCL
3	D4	DATA
4	D7	RX
5	D8	TX
6	3V	VCC
7	GND	GND
8	Vin	9V

From the picture above, an explanation of the telemetry system is obtained. The following is an explanation of the above circuit:

1. Polymer lithium battery as a voltage source from the NodeMCU module and voltage sensor.
2. VCC and GND from NodeMCU are the sources of the GPS module Neo 6M, DHT 11, and OLED display.
3. The red cable is a source of electric voltage (+), which will supply voltage to the esp8222, U-BLOX GPS module, OLED display, and DHT 11 sensor.
4. The blue cable will provide a source of electrical voltage (-), which will provide voltage to the esp8266, the U-BLOX GPS module, and the dht11 sensor.
5. The green input cable from pin D7 on the esp8266 connects to the RX pin on the U-blox Neo 6M GPS module.
6. The orange input cable from pin D8 on the esp8266 connects to the TX pin on the U-blox Neo 6M GPS module.
7. The pink input cable from pin D4 on the esp8266 connects to the data out pin on the DHT11 sensor.
8. The black wire input from pin D2 on the esp8266 connects to the SCL pin on the OLED display.
9. The yellow cable input from pin D1 on the esp8266 connects to the SDA pin on the OLED display.
10. The voltage source for the ESP8266 module comes directly from the lithium polymer battery.
11. A lithium polymer battery can be connected with a charger cable to be recharged when the battery runs out.

The following is an image of a telemetry system made using a rectangular black box to place the components used, such as the Nodemcu Esp8266 microcontroller, DHT11 temperature sensor, U-blox Neo 6M GPS module, OLED display, and breadboard.

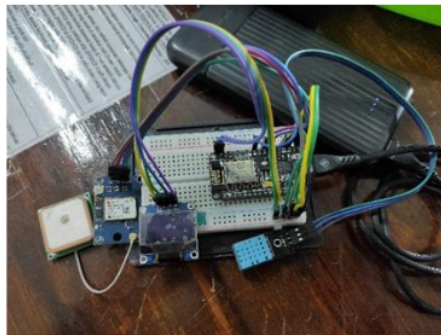

**Fig 5.** Tool Design Results





#### 4. Results and Discussion

The results and discussion in this study concern testing device function as a whole, including both hardware and software testing. Hardware testing (devices that have been assembled) and software testing (software that has been uploaded with the program), where the device has been installed on the imei-team electric car frame Testing using the Blynk application and also Thingspeak for monitoring data on the car through the DHT 11 sensor as a steering room temperature detector and also the U-blox Neo 6m GPS module as a car speed detector.

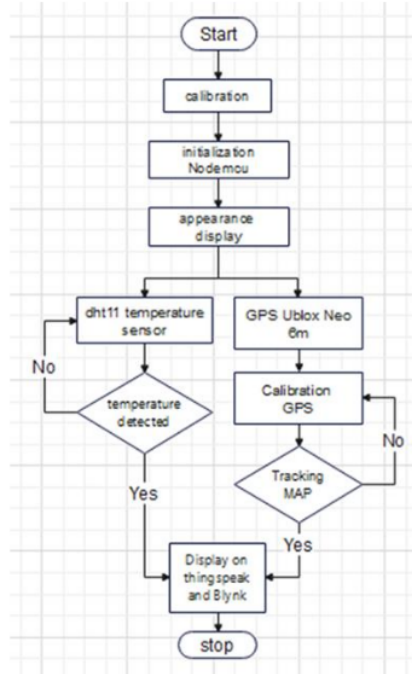

Fig 6. Flowchart diagram

The following explains the flowchart diagram used in the telemetry system. The program begins with system calibration. After calibration is complete, initialization of the NodeMCU microcontroller is carried out. Then, after initializing the NodeMCU, the system is on, and the display is on. Then the program will read data from the sensors used, which are the Neo U-blox 6M GPS sensor and the DHT11 sensor.

Furthermore, the sensor data is processed by the microcontroller to become actual data. Then the program will be grouped into two DHT11 temperature sensor readings and two U-blox Neo 6M GPS sensor readings. When the DHT-11 temperature sensor is read, it can be in one of two states: detected or not detected. The sensor will re-read the repetition data when the temperature is not detected. And when the DHT11 sensor is read, it will be forwarded to display on the system display in the form of Thingspeak, Blynk, and an OLED display. Then, the U-blox Neo 6M GPS sensor calibrates the satellite readings before reading the data generated by the sensor.

Then, after reading the GPS satellites, it will read the required data. There are two options for readings GPS will read the location or not. When the GPS does not read the location, the speed reading is also not read, and the system returns to the calibration process. If the GPS sensor is read, the speed and location data will be read and displayed via the Blynk interface. So after the respective sensor reads both, the ka will be displayed via the Blynk interface, Thingspeak, and the OLED display. Once it has been displayed, the reading of a system is complete.





#### 4.1 Program Result

Below is the program of the telemetry system using arduino ide software.

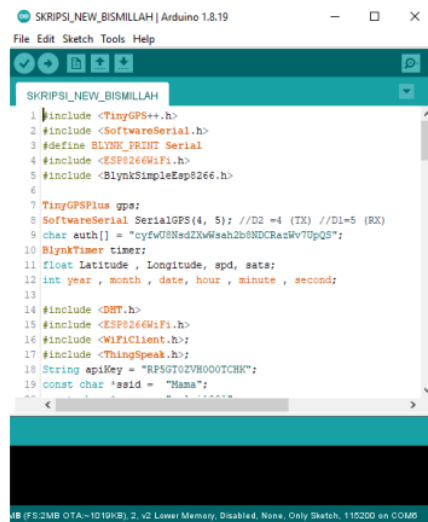

```

1 #include <TinyGPS++.h>
2 #include <SoftwareSerial.h>
3 #define BLYNK_PRINT Serial
4 #include <ESP8266WiFi.h>
5 #include <BlynkSimpleEsp8266.h>
6
7 TinyGPSPlus gps;
8 SoftwareSerial SerialGPS(4, 5); //D2 =4 (TX) //D1=5 (RX)
9 char auth[] = "cyfV08Hsd2ZkWhsh2b8NDCRsd3V7UpQ5";
10 BlynkTimer timer;
11 float Latitude , Longitude, spd, sats;
12 int year , month , date , hour , minute , second;
13
14 #include <DHT.h>
15 #include <ESP8266WiFi.h>
16 #include <WiFiClient.h>;
17 #include <ThingSpeak.h>;
18 String apiKey = "RPSGT0ZVR000TCHK";
19 const char *ssid = "Mama";
  
```

Fig 7. Programming sistem telemetry with Arduino IDE

#### 4.2 Testing temperature and speed with thingspeak

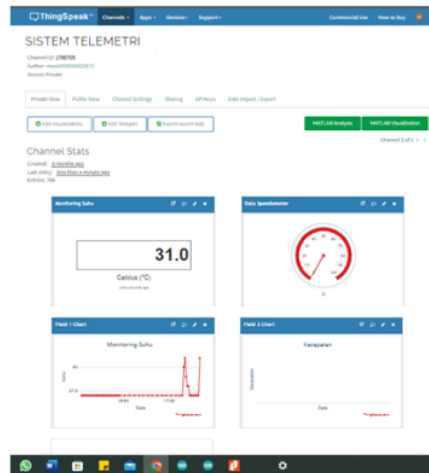
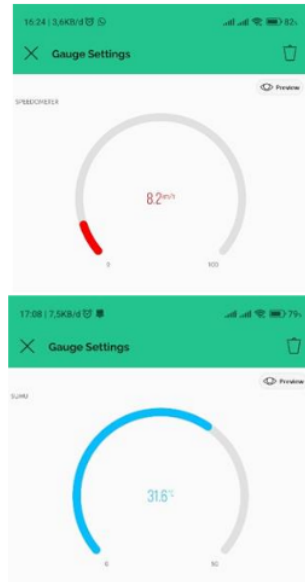

Fig 8 (a). View on Thingspeak



### 4.3 Testing temperature and speed with Blynk



**Fig 8(a).** View on Blynk

The picture purp<sup>4</sup>orts to show the Blynk and ThingSpeak interfaces being used to store data from a telemetry system. ThingSpeak is an IoT<sup>4</sup> platform that enables users to gather, process, and visualize sensor data in the cloud, whereas Blynk is an IoT platform that enables users to create mobile apps for IoT devices. They may be used to build a telemetry system that can gather and show data from numerous sensors.

Certain data points create various values in the results of evaluating the car's speed using the U-blox Neo 6m GPS sensor; however, the discrepancy between the data needed and the sensor's output data is not very wide. The test results are listed below.

**Table 2.** GPS sensor data table

Speedometer	Sensor GPS U-blox		
Speed (Km/H)	Testing 1	Testing 2	Testing 3
10	8	8	8
20	17	16	16
30	25	25	23
40	37	35	35
Average	21,27	21	20,5

From the test results of the dht11 temperature sensor, a result has been obtained that has been carried out three times at different times. Here are the results of the test.

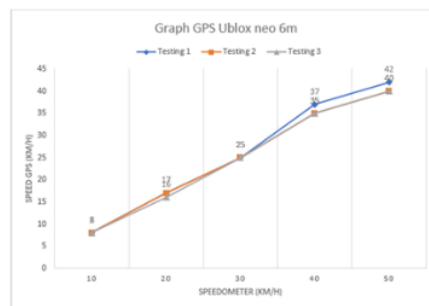



Table 3. DHT11 sensor data table

Minute	Sensor DHT 11		
	Testing 1	Testing 2	Testing 3
2	31,0	31,0	31,0
4	31,0	31,0	31,0
6	30,7	30,5	30,5
8	30,7	30,6	30,6
10	30,5	30,5	30,5

From the results of testing the telemetry system tool, a graph of the overall research results is obtained. The following is a graphical explanation of graphs 1 and 2.



Graph 1. GPS U-blox Sensor Data

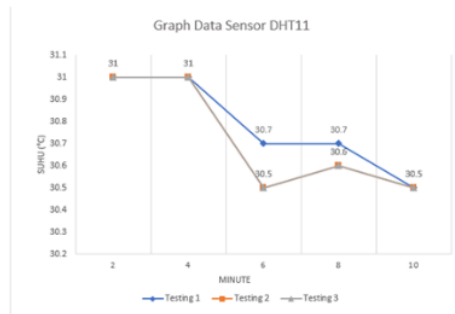

Graph 2. DHT 11 Sensor Data

## 5. Conclusion

Based on the test results and data analysis that have been done, the following conclusions are obtained :

1. This telemetry system can work optimally and quite well in its use because the coverage area is widespread and only limited by cellular networks.
2. Data transmission is still not real-time because there is a delay in the software (blank is 3 seconds late and thing speaks is 15 seconds late).
3. The use of the DHT-11 sensor is less stable because the room temperature on the steering wheel often changes.





## References

- [1] I. Car, "BAB I," pp. 1–10, 1993.
- [2] B. Losper, B. Groenewald, and V. Balyan, "Remote electrical vehicle communication system," in *2017 Fourth International Conference on Image Information Processing (ICIIP)*, 2017, pp. 1–4. doi:10.1109/ICIIP.2017.8313735.
- [3] M. R. Hammady, F. T. Elektro, and U. Telkom, "Sistem Telemetri Pada Mobil Listrik Inacos Berbasis Iot Universitas Telkom Telemetry System on Inacos Electric Car With Iot Concept Telkom University," vol. 5, no. 1, pp. 100–106, 2018.
- [4] M. Badri, J. T. Mesin, F. Teknik, and U. Riau, "Manufaktur Bodi Kendaraan Shell Eco Marathon (Sem) Tipe," vol. 4, no. 2, pp. 1–7, 2017.
- [5] A. G. Calderón, G. G. G. Ruiz, and A. C. G. Bohórquez, "GPRS telemetry system for high-efficiency electric competition vehicles," in *2013 World Electric Vehicle Symposium and Exhibition (EVS27)*, 2013, pp. 1–7. doi: 10.1109/EVS.2013.6914788.
- [5] A. G. Calderón, G. G. G. Ruiz, and A. C. G. Bohórquez, "GPRS telemetry system for high-efficiency electric competition vehicles," in *2013 World Electric Vehicle Symposium and Exhibition (EVS27)*, 2013, pp. 1–7. doi: 10.1109/EVS.2013.6914788.
- [6] M. Tadjuddin, U. Aulia, and T. Firsia, "Strategi Mengemudi Mobil Listrik Pada Kontes Mobil Hemat Energi (KMHE)," pp. 185–190, 2017.
- [7] M. Hemat and P. Tinggi, "Rancang bangun bodi mobiltuxuci politeknik tegal," vol. 3, pp. 37–40, 2014.
- [8] F. N. Falah, G. P. Adi, C. Saraswati, H. Prasetyo, Much. Djunaidi, and R. Fitriadi, "Penetapan Spesifikasi Desain Body Composite Untuk Urban Concept Berdasarkan Regulasi Kontes Mobil Hemat Energi 2018 Menggunakan Metode Quality Function Deployment (QFD)," *The 11th University Research Colloquium*, pp. 183–189, 2020.
- [9] N. Arina Hidayati *et al.*, "Analisis aerodinamis pada variasi bentuk ekor desain bodi mobil hemat energi," *Jurnal Energi Dan Manufaktur*, vol. 10, no. 2, pp. 66–70, 2018.
- [10] A. Wahab, M. Rohman, A. Saepuddin, and M. Sulaiman, "Desain Dan Simulasi Uji Kekuatan Chassis Mobil Sem Jenis Prototype Menggunakan Material Aluminium Alloy 7075," *Jurnal Teknik Mesin Indonesia*, vol. 17, no. 1, pp. 78–85, 2022, doi: 10.36289/jtmi.v17i1.297.
- [11] V. A. Iriciuc and A. Kotlar, "Sensor Monitoring System for Formula Student Car," in *2018 IEEE 24th International Symposium for Design and Technology in Electronic Packaging (SIITME)*, 2018, pp. 206–297. doi: 10.1109/SIITME.2018.8599259.
- [12] N. Nikolov, "Research of Automotive Infotainment System and its Design with IoT Connectivity," in *2022 13th National Conference with International Participation (ELECTRONICA)*, 2022, pp. 1–4. doi: 10.1109/ELECTRONICA55578.2022.9874420.
- [13] B. Losper, B. Groenewald, and V. Balyan, "Remote electrical vehicle communication system," in *2017 Fourth International Conference on Image Information Processing (ICIIP)*, 2017, pp. 1–4. doi: 10.1109/ICIIP.2017.8313735.
- [14] M. S. Maulana, I. Sulistiyowati, T. Elektro, and U. M. Sidoarjo, "Sistem Telemetri Mobil Listrik IMEI TEAM UMSIDA Berbasis Iot Dan Ublox Gps Neo-6m," pp. 1–5, 2000.
- [15] N.-M. Drogeanu, L.-A. Perișoară, and J.-A. Văduva, "Web Interface for IoT Vehicle Monitoring System," in *2022 IEEE 28th International Symposium for Design and Technology in Electronic Packaging (SIITME)*, 2022, pp. 185–190. doi: 10.1109/SIITME56728.2022.9988627.
- [16] I. H. Suprobo, A. Yuandari, A. Hartono, H. S. K, H. V. P. D. M, and Y. A. S, "Vol 3, 2021 SISTEM TELEMETRI MOBIL LISTRIK ARUGO," vol. 3, 2021.
- [17] V. Rahatal, P. More, M. Salunke, S. Makeshwar, and R. D. Joshi, "IoT Based Communication System for Autonomous Electric Vehicles," in *2021 7th International Conference on Signal Processing and Communication (ICSC)*, 2021, pp. 66–72. doi: 10.1109/ICSC53193.2021.9673164.
- [18] E. M. Antonyuk, I. E. Varshavskiy, I. S. Kolpakova, A. A. Minina, and P. E. Antonyuk, "Telemetry system with adaptive commutation," in *2016 IEEE NW Russia Young Researchers in Electrical and Electronic Engineering Conference (EIconRusNW)*, 2016, pp. 389–391. doi: 10.1109/EIconRusNW.2016.7448202.
- [19] M. A. Rafique, I. Alam, M. Tayyab, and A. Mustafa, "A cost and resource efficient telemetry host station design using FPGA," in *2018 15th International Bhurban Conference on Applied Sciences and Technology (IBCAST)*, 2018, pp. 799–804. doi: 10.1109/IBCAST.2018.8312315.





- [20] S. Taghizadeh, P. Jamborsalamati, M. J. Hossain, and J. Lu, "Design and Implementation of an Advanced Vehicle-to-Vehicle (V2V) Power Transfer Operation Using Communications," in *2018 IEEE International Conference on Environment and Electrical Engineering and 2018 IEEE Industrial and Commercial Power Systems Europe (EEEIC / I&CPS Europe)*, 2018, pp. 1–6. doi: 10.1109/EEEIC.2018.8494480.
- [21] G. Hristov, P. Zahariev, S. Borisov, and D. Kyuchukova, "An educational system for real-time monitoring and evaluation of the parameters of electric vehicles," in *2016 15th International Conference on Information Technology Based Higher Education and Training (ITHET)*, 2016, pp. 1–5. doi: 10.1109/ITHET.2016.7760757.
- [22] K. Z. Tang, S. Tang, N. P. Kusumadi, and S. H. Chuan, "Development of a remote telemetry and diagnostic system for electric vehicles and electric vehicle supply equipment," in *2013 10th IEEE International Conference on Control and Automation (ICCA)*, 2013, pp. 609–613. doi: 10.1109/ICCA.2013.6565203.
- [23] F. Firdaus and I. Ismail, "Komparasi Akurasi Global Positioning System (GPS) Receiver U-blox Neo-6M dan U-blox Neo-M8N pada Navigasi Quadcopter," *Elektron : Jurnal Ilmiah*, vol. 12, no. 1, pp. 12–15, 2020, doi: 10.30630/eji.12.1.137.
- [24] Siswanto, Firdiansyah, M. anif, and basuki hari Prasetyo, "Kendali dan Monitoring Ruang Server dengan Sensor Suhu DHT-11 Gas MQ-2 serta Notifikasi SMS," *Sistem Informasi dan Teknologi Informasi*, pp. 122–130, 2019.
- [25] I. Sulistiyowati, M. I. Muhyiddin, D. Elektro, and F. Sains, "Robot Penyemprotan Disinfektan untuk Mencegah Penularan Virus Covid-19 Berbasis Internet of Things ( IoT )," vol. 5, no. 2, pp. 61–67, 2021.





ORIGINALITY REPORT

---

12%

SIMILARITY INDEX

11%

INTERNET SOURCES

8%

PUBLICATIONS

10%

STUDENT PAPERS

---

PRIMARY SOURCES

---

1	Submitted to Universitas Islam Lamongan Student Paper	6%
2	Submitted to Universitas Merdeka Malang Student Paper	3%
3	<a href="http://ejournal.fortei7.org">ejournal.fortei7.org</a> Internet Source	1%
4	T. K. Rana, Naomi Mallik, Bidipta Dutta. "IOT Based String Failure Detection and Monitoring System", 2020 4th International Conference on Electronics, Materials Engineering & Nano-Technology (IEMENTech), 2020 Publication	<1%
5	Submitted to University of Hertfordshire Student Paper	<1%
6	<a href="http://complianceportal.american.edu">complianceportal.american.edu</a> Internet Source	<1%
7	<a href="http://www.scitechnol.com">www.scitechnol.com</a> Internet Source	<1%
8	<a href="http://eprints.unram.ac.id">eprints.unram.ac.id</a> Internet Source	

<1 %

9

Rodrigo N. Calheiros, Rajiv Ranjan, Anton Beloglazov, César A. F. De Rose, Rajkumar Buyya. "CloudSim: a toolkit for modeling and simulation of cloud computing environments and evaluation of resource provisioning algorithms", Software: Practice and Experience, 2011

Publication

<1 %

10

Angga Kengkongan Ary, Aditya Rio Prabowo, Fitriani Imaduddin. "Structural Assessment of an Energy-Efficient Urban Vehicle Chassis using Finite Element Analysis – A Case Study", Procedia Structural Integrity, 2020

Publication

<1 %

11

Muhammad Ogin Hasanuddin, Reihan Augeetiansyah, Gotawa Aryo Prakoso, Beni Rio Hermanto. "Design and Implementation of IMU, BLE Proximity and GPS-Based Theft Detection System", 2022 12th International Conference on System Engineering and Technology (ICSET), 2022

Publication

<1 %

12

[www.researchgate.net](http://www.researchgate.net)

Internet Source

<1 %

13

Wildan Arief Prasetyo, Arief Wisaksono, Indah Sulistiyowati. "Google Sheet-based Monitoring of Screw Turbine Pico Hydro Power Plant on Masangan Wetan Village's River Flow", *Procedia of Engineering and Life Science*, 2023

Publication

<1 %

---

Exclude quotes      On

Exclude matches      Off

Exclude bibliography      On